



HuMeij

ABOUT HUMEIJ

HuMeij Windshifters BV is the global leader in the design, manufacturing and commissioning of air classifiers with a unique pull-push mechanism. These Windshifters facilitate the recycling industry to reach their goals in the most sustainable and efficient ways.

Our top-notch air classifiers dispose of many adaptable options to create flexibility in integration.

We know exactly what recycling is about and what an air classifier needs to help you reach your goals. We design and develop a standard range of Windshifters that are built and configured to order.

HuMeij Windshifters BV

Steenbakkerstraat 10a
2222 AT Katwijk (ZH)
www.humeij.nl
info@humeij.nl
+31 71 785 76 94



25+
Years Of Experience

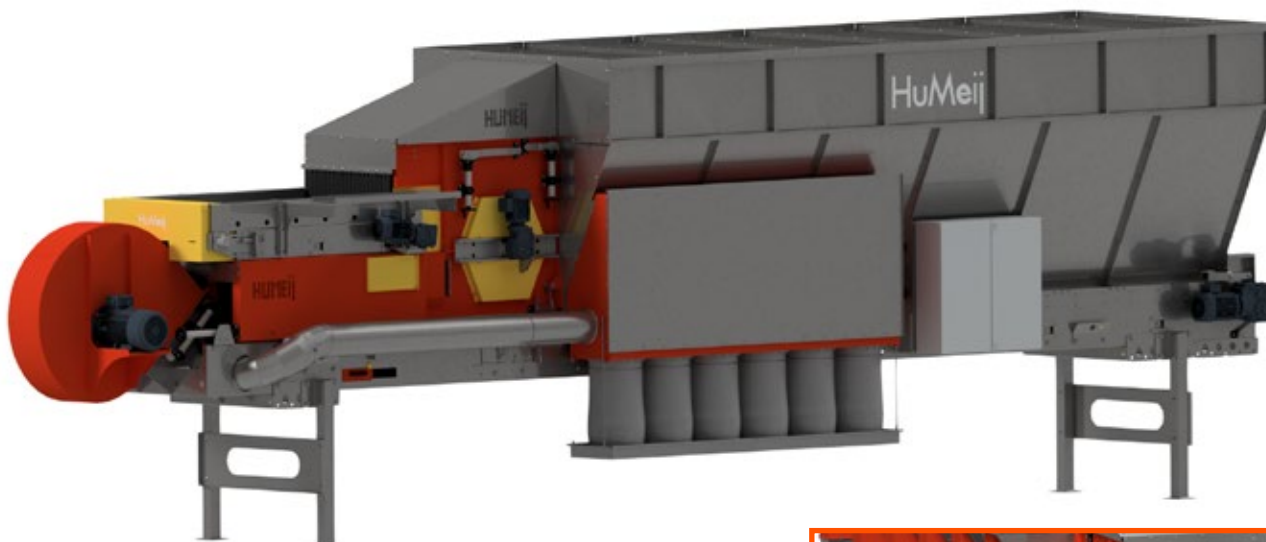

Advanced Windshifter Assembled splits materials in two fractions and facilitates in all types of waste treatments. Our Advanced Windshifter Assembled (AWA) is your all-round air classifier for in- and outdoor applications. The standard scope is plug and play.

DETAILS OF THE AWA:

- Available in nett width 550 until 950 mm of the infeed conveyor (increments of 200 mm)
- Handling material sizes up to 250 mm
- Capacity goes up to 100 m³/hour
- Adjustable pull-push circulated airflow
- Infeed conveyor is 250 mm moveable towards trommel, and is just like the valve easy adjustable without any tools
- The dedicated filter has a pre-separation chamber cleaning by a rotational motor and discharge of dust in plastic bags
- Disposes of an integrated particle buffer in blow channel
- Infeed and discharge conveyor can be reinforced if desired
- Can be reinforced for abrasive applications
- Standard scope is plug & play, but the filter, controls and legs can be excluded
- Shipment per tilt trailer or 40' HC containers



Advanced Windshifter splits materials in two fractions and facilitates in all types of waste treatments. Our Advanced Windshifter (AW) is your all-round air classifier for in- and outdoor applications. The machine is delivered in efficient sub-assemblies for easy shipment and handling.

Details of the AW:

- Available in nett width 750 until 1950 mm of the infeed conveyor (increments of 200 mm)
- Handling material sizes up to 600 mm
- Capacity goes up to 200 m³/hour
- Adjustable pull-push circulated airflow
- Infeed conveyor is 500 mm moveable towards trommel, and is just like the valve easy adjustable without any tools
- Filter position can be placed up to 20 m from the fan
- Disposes of a standard filter including cleaning by regenerating fans and manual slide valves for discharge of dust
- Rotary valve is available on the filter for discharge of dust
- Disposes of a single and flexible position of the fan for the whole range
- Disposes of an integrated particle buffer in blow channel
- Discharge conveyor standard inclined up to 15 degrees
- Infeed and discharge conveyor can be reinforced if desired
- Can be reinforced for abrasive applications
- Structure and platform are available
- Shipment per tilt trailer or 40' HC containers



Premium Windshifter splits materials in three fractions and is suitable for all kinds of waste. The HuMeij Premium Windshifter (PW) is a unique air classifier with a range of both indoor and outdoor possibilities. The machine is delivered in efficient sub-assemblies for easy shipment and handling.

DETAILS OF THE PW:

- Available in nett width 750 until 1950 mm of the infeed conveyor (increments of 200 mm)
- Handling material sizes up to 600 mm
- Capacity goes up to 200 m³/hour
- Adjustable pull-push circulated airflow
- Infeed conveyor is 500 mm moveable towards trommel, and is just like the valve easy adjustable without any tools
- Filter position can be placed up to 20 m from the fan
- Disposes of a single fan up to PW135 and a double fan for PW 155 up to PW195
- Disposes of an integrated particle buffer in blow channel
- Disposes of a standard filter including cleaning by regenerating fans and manual slide valves for discharge of dust
- Rotary valve is available on the filter for discharge of dust
- Discharge conveyor standard inclined up to 15 degrees
- Infeed and discharge conveyor can be reinforced if desired
- Can be reinforced for abrasive applications
- Structure and platform are available
- Shipment per tilt trailer or 40' HC containers



Flex Windshifter and Flex Windshifter Pull splits packaging materials in two fractions and is suitable for extracting film and fiber. Our Flex Windshifter (FW) and Flex Windshifter Pull (FWP) are your all-round air classifier for indoor applications. The machine is delivered in efficient sub-assemblies for easy shipment and handling.

DETAILS OF THE FW:

- Available in nett width until 2400 mm of the infeed conveyor
- Available without pushnozzle (FWP)
- Available in ZigZag
- Available in as vacuumhood over conveyor (FOC)
- Available with recirculated suctionhoods for manual sorting
- Capacity lights go up from 3.5 t/hour
- Adjustable pull-push circulated airflow
- Filter position can be placed up to 20 m from the fan
- Provides for new or retrofit and has great flexibility in positioning drop zone lights
- The Flex Windshifter will be fitted on dedicated conveyor
- The lights will be transported through ducts into the Mechanical Film Separator (MFS)
- Disposes of a standard filter including cleaning by regenerating fans and manual slide valves for discharge of dust
- Rotary valve is available on the filter for discharge of dust
- Shipment per tilt trailer or 40' HC containers

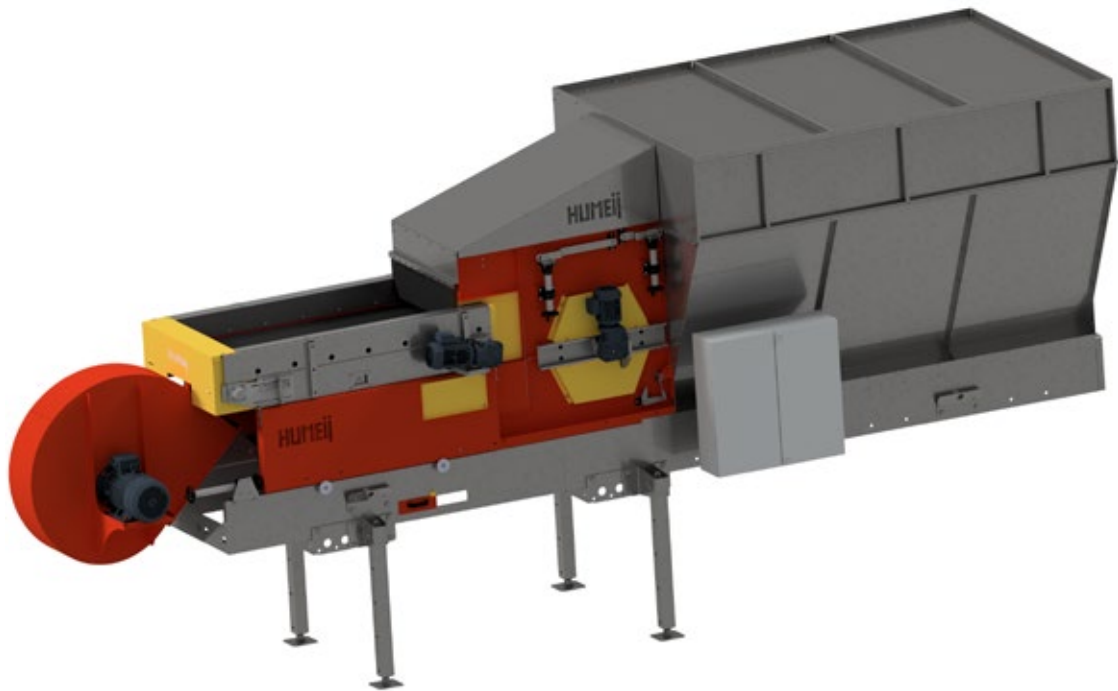

Advanced Blower Assembled splits waste into two fractions and upgrades fines & biomass. The HuMeij Advanced Blower Assembled (ABA) is a Windshifter especially designed for outdoor applications. The standard scope is plug & play.

DETAILS OF THE ABA:

- Available in nett width 750 until 1150 mm of the infeed conveyor (increments of 200 mm)
- Handling material sizes up to 250 mm
- Capacity goes up to 120 m³/hour
- 100% pull-push circulated airflow
- Infeed conveyor is 250 mm moveable towards trommel, and is just like the valve easy adjustable without any tools
- Disposes of an integrated particle buffer in blow channel
- Infeed conveyor can be reinforced if desired
- Can be ordered without electrical cabinet or legs
- Shipment per tilt trailer or 40' HC containers